

**1. Part Number:** A616-100

**2. Photograph:**

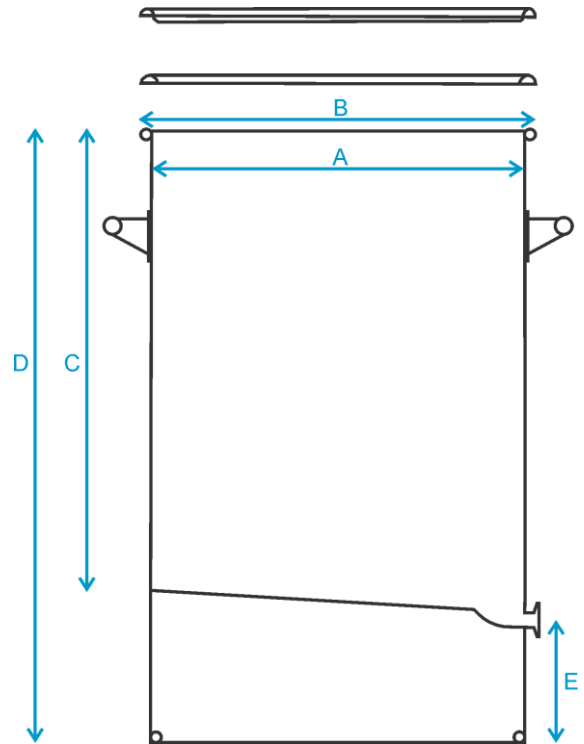

### 3. Product Information:

**Description**

Stainless Storage Drum 100L with 1.5" Ferrule

**Materials of Construction:**

- Body: 316L stainless steel
- Ferrule: 316L stainless steel
- Lid: 316L stainless steel
- Clamp: 304 stainless steel
- Handles: 304 stainless steel
- Gasket: Silicone (FDA 177.2600 and USP Class VI compliant)

**Nominal Volume:**

100 Litres

**Method of Construction:**

- Welds ground and polished
- Crevice free interior

**Surface Finish:**

Better than 0.5 microns Ra

**Nominal Dimensions:**

A = 470 mm  
B = 494 mm  
C = 587 mm  
D = 787 mm  
E = 170 mm

**Graduation Marks:**

None

**Ferrule:**

1.5" (to standard BS4825-3)

**Handles:**

2 side handles welded onto patch plates

**Weight:**

18.1 kg (body + gasket + lid + clamp)

BSE/TSE statement:

All polishing compounds used in the manufacture of this product are of vegetable origin

Recommended Storage Conditions:

Dry and ambient temperature

Notes:

- This product should be thoroughly cleaned before it is used for the first time
- Discharge valve is not included

#### 4. Approval:

Signed:



Name: Kuldeep Flora

Position: Quality Manager

Date: 7-Jan-25