

**1. Part Number:** A126-50

**2. Photograph:**

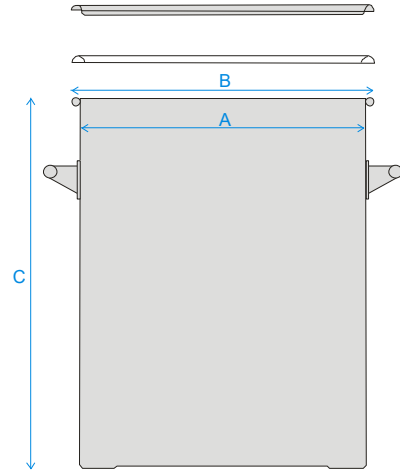

**3. Product Information:**

Description

Stainless Storage Drum 50L

Materials of Construction:

- Body: 316L stainless steel
- Lid: 316L stainless steel
- Clamp: 304 stainless steel
- Handles: 304 stainless steel
- Gasket: Silicone (FDA 177.2600 compliant & BSE/TSE free)

Nominal Volume:

50 Litres

Brimful Volume:

52 Litres

Method of Construction:

Welds ground and polished

Surface Finish:

Better than 0.5 microns Ra

Dimensions

A = 394 mm  
B = 414 mm  
C = 430 mm

Drum Wall Thickness:

1.2mm

Graduation Marks:

None

Handles:

2 side handles welded onto patch plates

Weight:

8.6 Kg (body + gasket + lid + clamp)

BSE/TSE statement:

All polishing compounds used in the manufacture of this product are of vegetable origin.

Recommended Storage Conditions:

Dry and ambient temperature

**4. Approval:**

Signed:



Name: Kuldeep Flora

Position: Quality Manager

Date: 14-Aug-20

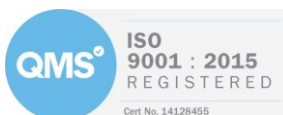

**Sampling Systems Ltd.**

4-5 Forge Mills Park, Coleshill, Warwickshire, B46 1JH, UK.

Tel: +44(0)1675 466992 Email: info@sampling.com Web: www.sampling.com