

**1. Part Number:** A126-100

**2. Photograph:**

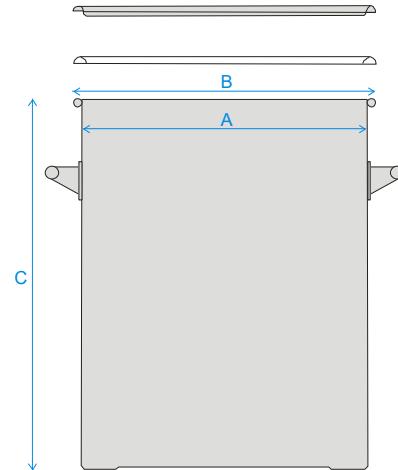

**3. Product Information:**

|                                 |   |
|---------------------------------|---|
| Description                     | Stainless Storage Drum 100L   |
| Materials of Construction:      | <ul style="list-style-type: none"> <li>- Body: 316L stainless steel</li> <li>- Lid: 316L stainless steel</li> <li>- Clamp: 304 stainless steel</li> <li>- Handles: 304 stainless steel</li> <li>- Gasket: Silicone (FDA 177.2600 compliant &amp; BSE/TSE free)</li> </ul> |
| Nominal Volume:                 | 100 Litres  |
| Brimful Volume:                 | 105 Litres  |
| Method of Construction:         | Welds ground and polished   |
| Surface Finish:                 | Better than 0.5 microns Ra  |
| Dimensions                      | <ul style="list-style-type: none"> <li>A = 470 mm</li> <li>B = 490 mm</li> <li>C = 610 mm</li> </ul>  |
| Drum Wall Thickness:            | 1.2mm   |
| Graduation Marks:               | None  |
| Handles:                        | 2 side handles welded onto patch plates   |
| Weight:                         | 13.1 Kg (body + gasket + lid + clamp)   |
| BSE/TSE statement:              | All polishing compounds used in the manufacture of this product are of vegetable origin.  |
| Recommended Storage Conditions: | Dry and ambient temperature   |

**4. Approval:**

Signed:



Name: Kuldeep Flora

Position: Quality Manager

Date: 14-Aug-20